

# Boy-/Girlband-medley

1. Bootylicious // 2. Bye Bye // 3. Survivor // 4. Everybody get up //  
5. The Tide is High // 6. I Want It That Way // 7. Ademnood // 8. What Makes  
You Beautiful // 9. Meidengroep // 10. Stop //  
11. Picture of You // 12. I'm So Excited



## 1 . Bootylicious (Destiny's Child)

### Handle 1

Various Artists  
Arr. Steven Favier

$\text{♩} = 103$

*Dirigent:* *Alle dames:*

S. Blend, can you han-dle this? Men, can you han-dle this?

5 *Alle heren:* *Hele koor:*

S. La - dies, can you han - dle this? I don't think you can han - dle this.

T. I don't think you can han - dle this.

### Chorus

7 *Hele koor uni (T 8vb)*

S. I don't think you're rea - dy for this me - dley I \_\_\_ don't think you're rea - dy for this med - ley. I \_\_\_

9

S. \_\_\_ don't think you're rea - dy for this, 'cause my voice is too de - li - cious for \_\_\_ you babe.

11 *(dames div)*

S. I don't think you're rea - dy for this med - ley I \_\_\_ don't think you're rea - dy for this med - ley. I \_\_\_

A. I don't think you're rea - dy for this med - ley I \_\_\_ don't think you're rea - dy for this med - ley. I \_\_\_

T. I don't think you're rea - dy for this med - ley I \_\_\_ don't think you're rea - dy for this med - ley. I \_\_\_

13

S. \_\_\_ don't think you're rea - dy for this,

A. \_\_\_ don't think you're rea - dy for this,

T. \_\_\_ don't think you're rea - dy for this, 'cause my voice is too de - li - cious for \_\_\_ you babe. V.S.

**Handle 2**

Koor S(M)AT(B)

15 *Alle dames (tegen de heren):*

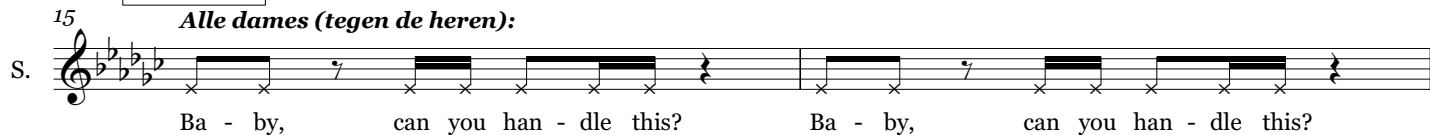
S. 

Ba - by, can you han - dle this? Ba - by, can you han - dle this?

17 

Ba - by, can you han-dle this? I don't think you can han-dle this. **Booh/Aah**  
Gejoel, boe, etc.

21 **Intro**

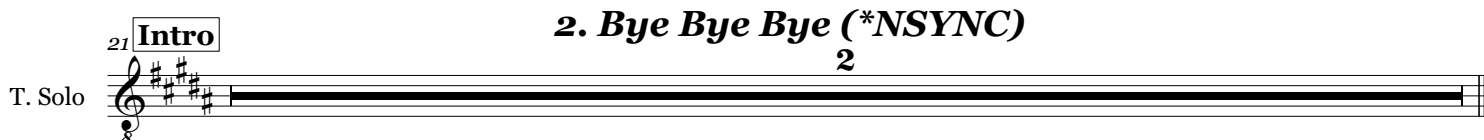
T. Solo 

**2. Bye Bye Bye (\*NSYNC)**

23 **Verse**

T. 

I'm do-ing this to nightyou're pro-b'bly gon-na start a fight, I know this can't be right, hey ba-by, come on.

27 **PC**

T. 

I know that I can't take no more, it ain't no lie... I want to see you out that door, ba-by bye bye bye...

31 **Chorus**

T. 

Don't want to be a fool for you, just a-no-ther pla-yer in your game for two. You may hate me but it

34 

ain't no lie, ba-by bye bye bye... Don't real-ly want to make it tough I just want to tell you that I've had e-nough.

37 

it might sound cra - zy, but it ain't no lie, ba - by bye bye bye...

### 3. Survivor (Destiny's Child)

♩=83 **Intro**

S. *Alle dames:*  
Now that you're

**Verse**

S. out-ta my life, I'm so much bet-ter You thought that I'd be weak with-out ya, but I'm stron-ger. You thought that I'd be

S. broke with-out ya, but I'm ri-cher, You thought that I'd be sad with-out ya, I love har-der. Thought I would-'nt

S. grow with-out ya, now I'm wi ser. Thought that I'dbe help-less with-out ya, but I'm smar-ter. You thought that I'dbe

S. stressed with-out ya, but I'm chil-lin', thought I would-'nt sell with-out ya, sold nine mil-lion. I'm a sur-

**Chorus**

S. vi - vor, I'm not gon' give up, I'm not gon' stop, I'm gon' work har - der. I'm a sur -

A. *"Stoer":*  
 What what what what.

S. vi - vor, I'm gon - na make it, I will sur - vive, keep on sur - vi - ving. I'm a sur -

A. what what what I'm a sur - V.S.

## Koor S(M)AT(B)

55 *G#m C#m D# G#m D#*

S. vi - vor, I'm not gon' give up, I'm not gon' stop, I'm gon' work har - der. I'm a sur -

A. vi - vor, I'm not gon' give up, I'm not gon' stop, I'm gon' work har - der. I'm a sur -

T. *"Spottend"*  
What what what what.

57 *G#m C#m D# G#m D#*

S. vi - vor, I'm gon - na make it, I will sur - vive, keep on sur - vi - ving.

A. vi - vor, I'm gon - na make it, I will sur - vive, keep on sur - vi - ving.

T. what what what what.

**4. Everybody get Up (Five)**

59 *C<sup>5</sup>* *"Stoer-doenerij", gejoel, etc.*

T. **Intro** **3**

**Chorus**

64 *C<sup>5</sup> F<sup>5</sup> G<sup>5</sup>* *Alle dames, "verveeld"*

S. One, two, three, four

T. Ev - 'ry - bo\_\_ dy get up sing - in'.

66 *C<sup>5</sup> F<sup>5</sup> C<sup>5</sup>* *"Uitdagend"*

S. Bring it on, bring it on, bring it on, bring it on.

T. Five will make you get down now. Ev - 'ry - bo\_\_ dy get up sing - in'.

69 *F<sup>5</sup> G<sup>5</sup> C<sup>5</sup> F<sup>5</sup>*

S. One, two, three, four Bring it on, bring it on, The

T. Five will make you get down now.

**Chorus****5. Mashup met Tide is high (Atomic Kitten)**

72 C<sup>5</sup> F<sup>5</sup> G<sup>5</sup> C<sup>5</sup> F<sup>5</sup>

S. tide is high, but I'm hol - din' on. I'm gon - na be your num - ber one. The

T. Ev-'ry-bo\_ dy get up sing-in'. Five will make you get down now.

76 C<sup>5</sup> F<sup>5</sup> G<sup>5</sup> C<sup>5</sup> F<sup>5</sup>

S. tide is high, but I'm hol - din' on. I'm gon - na be your num - ber one.

T. Ev-'ry-bo\_ dy get up sing-in'. Five will make you get down now.

80 C F G C S/M div F G

S. I'm\_ not the kind a girl, who gives up, just\_ like that.\_ Oh, no.\_

A. I'm\_ not the kind a girl, who gives up, just\_ like that.\_ Oh, no.\_

**Intro****6. I Want It That Way (Backstreet Boys)**

84 ♩=99 3 Solo tenor Verse

T. Solo You are, my fire. The one, de -

91 C G Em C G Em D G

T. Solo sire. Be - lieve, when I say: I want it that way. Tell me

**Chorus**

96 C(add2) D Em C(add2) D Em

T. Solo  
8 why... Tell me why...

T.  
8 (div) Ain't no-thing but a heart - ache. Ain't no-thing but a mis - take, - tell me

100 C(add2) D G Em D G

T. Solo  
8 I ne-ver wan-na hear you say. I want it that way.

T.  
8 why. I want it that way.

**7. Ademnood (Linda, Roos & Jessica)**

♩=100, 16's shuffled

**Intro***Alle dames:*

104 Fm Eb Bb Cm Bb Ab Fm7 Fm Eb Bb Cm Bb Ab Eb Eb(sus4) Eb

S.  
Na na na, na na na na na... Na na na, na na na na na...  
(Opt. 104-105 weglaten voor makkelijkere overgang)

**Verse**

112 Cm7 Bb/D Eb Eb(sus4) Eb Bb/D

A.  
Van-nacht was hef - tig, je krijgt van mij een dik-ke tien. Oh.

116 Cm7 Bb/D Eb Eb(sus4) Eb Db/F

S.  
'k Ging voor je li - chaam, daar-na zou ik wel ver-der zien. Hey.

**PC**

120 Gb Ab Bb Bb(sus4) Bb

S.  
Als je straks wak-ker wordt, laat ik je nooit meer gaan.

A.  
En nu de mor-gen komt, lig jij te-gen me aan. Je komt in

**Chorus**

124 Fm Eb Bb Cm Bb Ab Fm7

(div)

S. a - dem - nood, want de kans is groot dat ik krijg wat ik wil van jou, mond op mond, we doen het nou.

A. a - dem - nood, want de kans is groot dat ik krijg wat ik wil van jou, mond op mond, we doen het nou.

128 Fm Eb Bb Cm Bb Ab Fm/Ab Ab

(div)

S. a - dem - nood, geef je nu\_\_ maar bloot.\_\_ De - len we\_\_ de pas - sie weer,

A. a - dem - nood, geef je nu\_\_ maar bloot.\_\_ De - len we\_\_ de pas - sie weer,

131 Gm/Bb Bb Eb Eb(sus4) Eb

S. of wordt dit\_\_ de laat - ste keer\_\_ voor jou.\_\_ Hoh.\_\_\_\_

A. of wordt dit\_\_ de laat - ste keer\_\_ voor jou.\_\_ Hoh.\_\_\_\_

**8. That's what makes you beautiful (One Direction)****Intro**

134 ♩=125 straight

T. **3**

You're in - se -

**Verse**

138 C F G C F G

T. cure, don't know what for. You're tur-ning heads when you walk through the do - o - r.

**PC**

142 C F Am G C F

T. E - v'ry-one else in the room can see\_\_ it, e - v'ry-one else but\_\_ you - ou. Ba - by, you

**Chorus 1**

146 C F G C F G

T. light up\_\_ my world like no - bo - dy else, the way that you flip\_\_ your hair gets me o - ver - whelmed. But when you

150 C F Am G C

T. smile at\_\_ the ground, it ain't hard to tell you don't kno - oh - ow. You don't know you're beau - ti - ful.

**Chorus 2**

Koor S(M)AT(B)

154 C F G C F G

T.

If on - ly you saw what I can see, you'll un-der stand why I want you. so des-p'ret-ly. Right now I'm

158 C F Am G C F

T.

look - ing at you and I can't be - lieve you don't kno - oh - ow.

161 Am G C F G

T.

You don't know you're beau - ti - ful, oh oh. That's what makes you beau - ti - ful.

**9. Meidengroep (Kinderen voor Kinderen)**

164 **Chorus** D G

S.

Hou maar op ik blijf er bij dat zij met mij gaat zin-gen in een mei-den-groep. Dat is iets wat ik al

A.

Hou maar op ik blijf er bij dat zij met mij gaat zin-gen in een mei-den-groep. Dat is iets wat ik al

169 D G D

S.

tij-den roep, al - les lie-ver dan kan toor. Hou maar op ik blijf er bij dat zij met mij gaat zin-gen in een

A.

tij-den roep, al - les lie-ver dan kan toor. Hou maar op ik blijf er bij dat zij met mij gaat zin-gen in een

174 G C G D

S.

mei-den-groep. Wat is er mooi-er dan zo'n vrij be-roep, we wil-len bij zo'n groep, we zet-ten door.

A.

mei-den-groep. Wat is er mooi-er dan zo'n vrij be-roep, we wil-len bij zo'n groep, we zet-ten door.



**Intro**

180  $\text{♩} = 130$

T. Solo

**10. Stop (Spice Girls)**

8

**Verse**

188

F Eb Dm C

T. You just walk in, I make you smile, it's cool but you\_\_ don't e - ven know me.\_

192

F Eb Dm C B $\flat$  F/A Gm

T. You take an inch, I run a mile, can't win you're a - ways right be-hind me.\_

**PC**

196

Gm B $\flat$  F/A Gm B $\flat$  F/A Gm

T. Don't you know it's go - ing too fast, ra - cing so hard, you know it won't last.

200

Gm Am<sup>7</sup> B $\flat$  $\Delta$  C

T. Don't you know, what can't you see, \_ slow it down, \_ read the sign, so you know \_ just where you're go - ing.

**Chorus 1**

204

F Eb<sup>6</sup> Dm C

T. Stop right now, thank\_\_ you ve - ry much. I need some - bo - dy with a hu - man touch.\_

208

F Eb<sup>6</sup> Dm C

T. Hey, you, al - ways on the run, got - ta slow it down, ba - by, got - ta have some fun.\_

**Post-chorus**

212

F Eb<sup>6</sup> Dm C

T. Do do do do, do do do do, do do do al - ways be to - ge - ther.\_

216

F Eb<sup>6</sup> Dm C

T. Ba da pa pa, ba da pa pa, ba da pa stay\_\_ that way for - e - ver.\_

## 11. Picture of You (Boyzone)

**PC** F/G Dm C F/G B $\Delta$ /C C

220 *Alle dames (zoeken toenadering naar de mannen)*

S. 

You will be there when I need - ed some - bo - dy, you will be there, the on - ly one could help me...

**Chorus**

224 F Am/E Cm<sup>7</sup> B $\flat$  C

S. 

I \_\_\_\_\_ had a pic - ture of you in my mind, ne - ver knew it could be so wrong,  
(Mannen draaien bij, worden enthousiast)

228 F Am/E Cm<sup>7</sup> B $\flat$  C

*"Battle is over." Nu met z'n allen!*

S. 

Why'd it take me so long just to find the friend that was there all a - long?

A. 

Why'd it take me so long just to find the friend that was there all a - long?

T. 

Why'd it take me so long just to find the friend that was there all a - long?

**Outro**

232 F

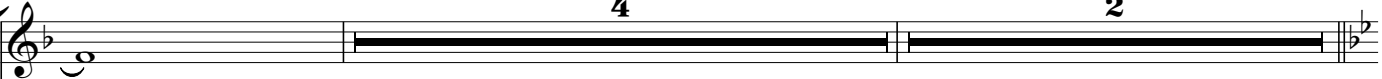
S. 

4 accel. 2

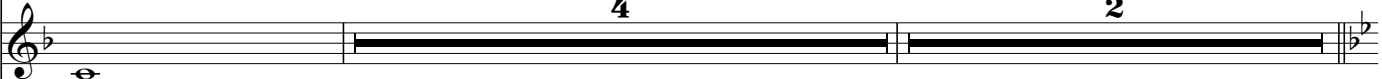
A. 

4 2

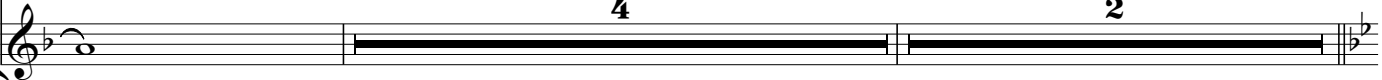
T. 

4 2

## 12. I'm So Excited (Pointer Sisters)

**Intro**  $\text{♩} = 180$

239 **7**

**Verse**  
(Alten)  $Gm^7$

A.  To - night's\_ the night we're gon - na make it hap

249  $Bb/C$   $Cm^7$   $Bb/Eb$   $Eb$   $Eb/Bb$   $Bb$

A.  - pen, to - night\_ we'll put\_ all\_ o-ther things a - side.\_

254  $Gm^7$   $Bb/C$   $Cm^7$   $Bb/Eb$   $Eb$

T.  Give in\_ this time and show me some af-fec - tion, we're going for\_ those plea-sures in the night.

261  $Eb/Bb$   $Bb$   $Am^7$  **PC**  $Gm^7$   $Dm^7$   $Am^7$

S.  I want to love you, feel you, wrap my-self a-round\_ you. I want to squeeze you,

A.  Love you, feel you. Squeeze you,

T.  Love you, feel you. Squeeze you,

268  $Gm^7$   $Cm^7$   $Dm^7$   $Eb/F$   $Gm^7$

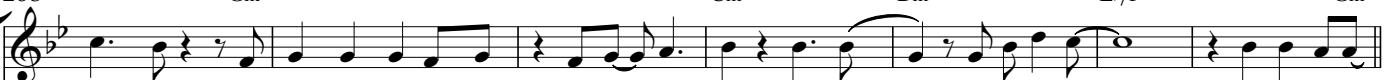
S.  please you, I just can't get e-nough. And if\_ you move real slow, \_ I'll let it go. \_ I'm so ex-ci

A.  please you. Oo\_ I'm so ex-ci

T.  please you. Oo\_ I'm so ex-ci V.S.

**Chorus**

Koor S(M)AT(B)

275

S. *E<sub>b</sub>* *F* *E<sub>b</sub>* *F* *Gm<sup>7</sup>*  
 - ted, I just can't hide\_\_ it. I'm a-bout to lose con-trol\_\_ and I think I like\_\_ it.

A. - ted, I just can't hide\_\_ it.

T. - ted, I just can't hide\_\_ it.

282

S. *Gm<sup>7</sup>* *E<sub>b</sub>* *F* *E<sub>b</sub>* *F* *Gm<sup>7</sup>*  
 I'm so ex-ci - ted, and I just can't hide\_\_ it. I know, I know, I know, I know, I know I

A. I'm so ex-ci - ted, and I just can't hide\_\_ it. I know, I know, I know, I know, I know I

T. I'm so ex-ci - ted, and I just can't hide\_\_ it. I know, I know, I know, I know, I know I

289

S. *S div* *Gm<sup>7</sup>* **Finale**  
 want you, I want you. I'm so ex-ci - ted, I just can't hide\_\_ it.

A. *Mezzo's  
Alten*  
 want you, I want you. Look what you do to me, you got me

T. want you, I want you. Look what you do to me, you got me

294

S. *E<sub>b</sub>* *F* *Gm<sup>7</sup>*  
 I'm a-bout to lose con-trol\_\_ and I think I like\_\_ it. I'm so ex-ci-

A. bur-nin' up\_\_ Oh. wow.

T. bur-nin' up\_\_ Oh. wow.

299

S.  - ted, and I just can't hide it.

A.  How did you get to me, I've got to give it up.

T.  How did you get to me, I've got to give it up.

303

S.  I know, I know, I know, I know, I know I want you, I want you.

A.  I know, I know, I know, I know, I know I want you, I want you.

T.  I know, I know, I know, I know, I know I want you, I want you.